

APPENDIX B

SEMANTIC STRUCTURE ANALYSIS DISPLAYS

### Abbreviations Used In Semantic Structure Analysis Displays

alt	alternation/ alternate	int	introduction
amp/AMP	amplification	[IRO]	irony
ANA	anacoluthon	[LIT]	litotes
ANS	answer	man	manner
CCL	conclusion	[MET]	metaphor
cir	circumstance	mns	means
cls	closing	[MTY]	metonymy
CNC	concept	mov	move
cnd	condition	neg	negative
cns	concession	occ/OCC	occasion
cnj	conjoining	op	opening
CNT	content	ori/ORI	orienter
com	comment	OUT	outcome
CON/con	contraction	par	parenthesis
cpr	comparison	(pl)	plural
CP	counter-proposal	pos	positive
CQ	counter-question	PRB	problem
CR	counter-remark	pri	preliminary
CNQ	consequence		incident
ctf	contrary-to-fact	prm	prominence
ctr	contrast	prp	proposal
CTX	contraexpectation	[PRS]	personification
dsc	description	pur	purpose
eqv	equivalent	que	question
[EUP]	euphemism	RCT	reaction
EVA	evaluation	rea	reason
evi	evidential	REP	reply
exc	exchange	RES	result
(exc)	exclusive	[RHQ]	rhetorical
EXE	execution		question
EXH	exhortation	rmk	remark
fig	figurative	RSL	resolution
GEN	generic	seq	sequential
GOL	goal	set	setting
grd	grounds	sim	simultaneous
HD	head	[SIM]	simile
[HEN]	hendiadys	(sg)	singular
[HYP]	hyperbole	spf	specific
[IDM]	idiom	stp	step
idn	identification	sum/SUM	summary
ill	illustration	[SYN]	synecdoche
(inc)	inclusive	tim	time
		tpc	topic

NOTE: Capitalization of relational roles indicates prominence, either natural or marked. Figures of speech (in brackets) are also capitalized. HD (Head) is often used in place of the more prominent role label.

Episode Schema

Communicati

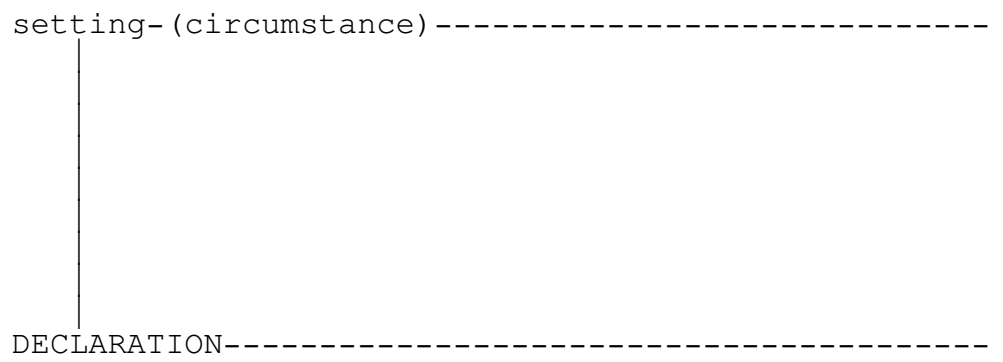

Episode Schema

Communicati

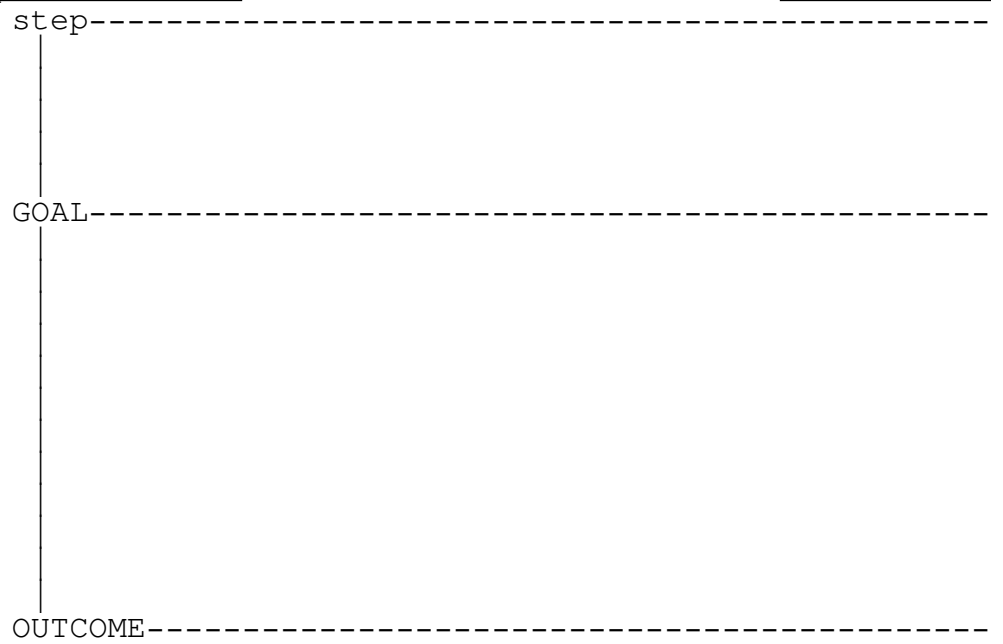

Episode Schema

Communicati

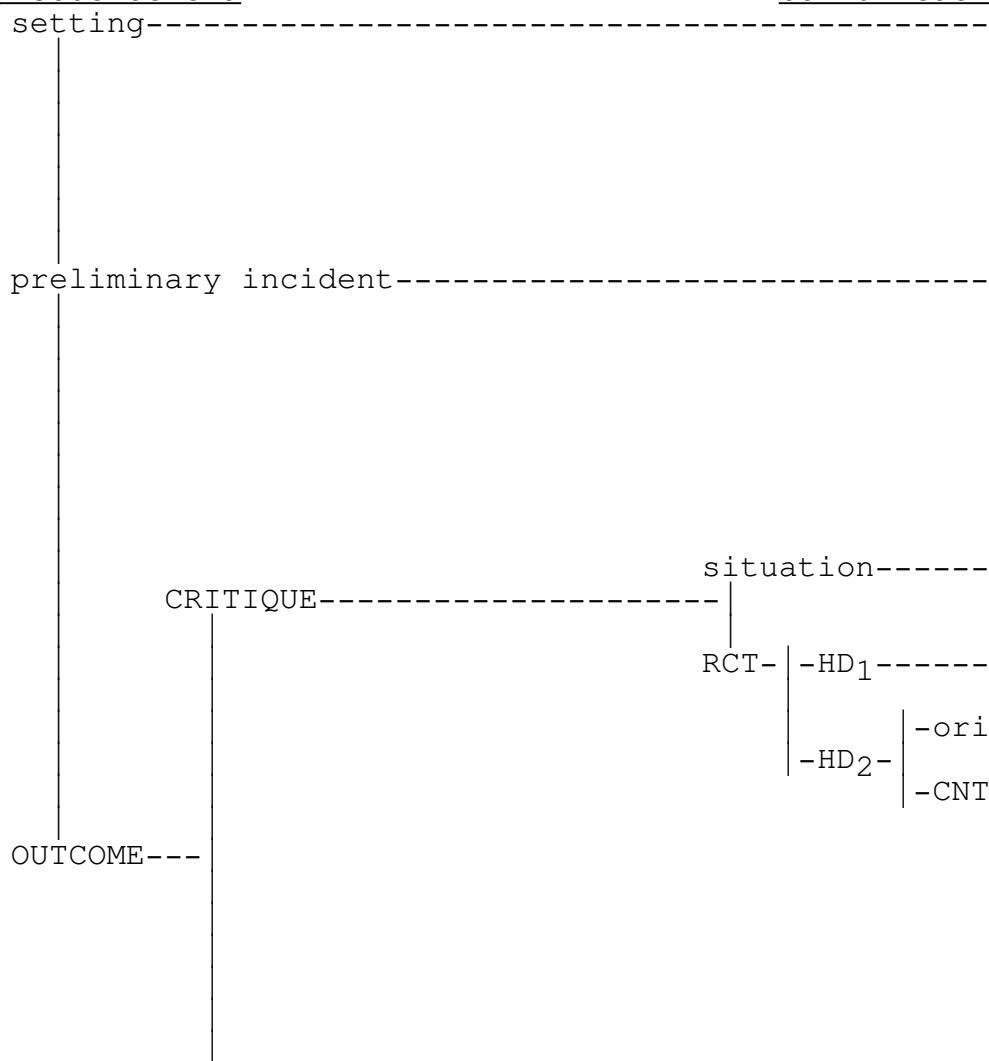

Episode Schema

Communicati

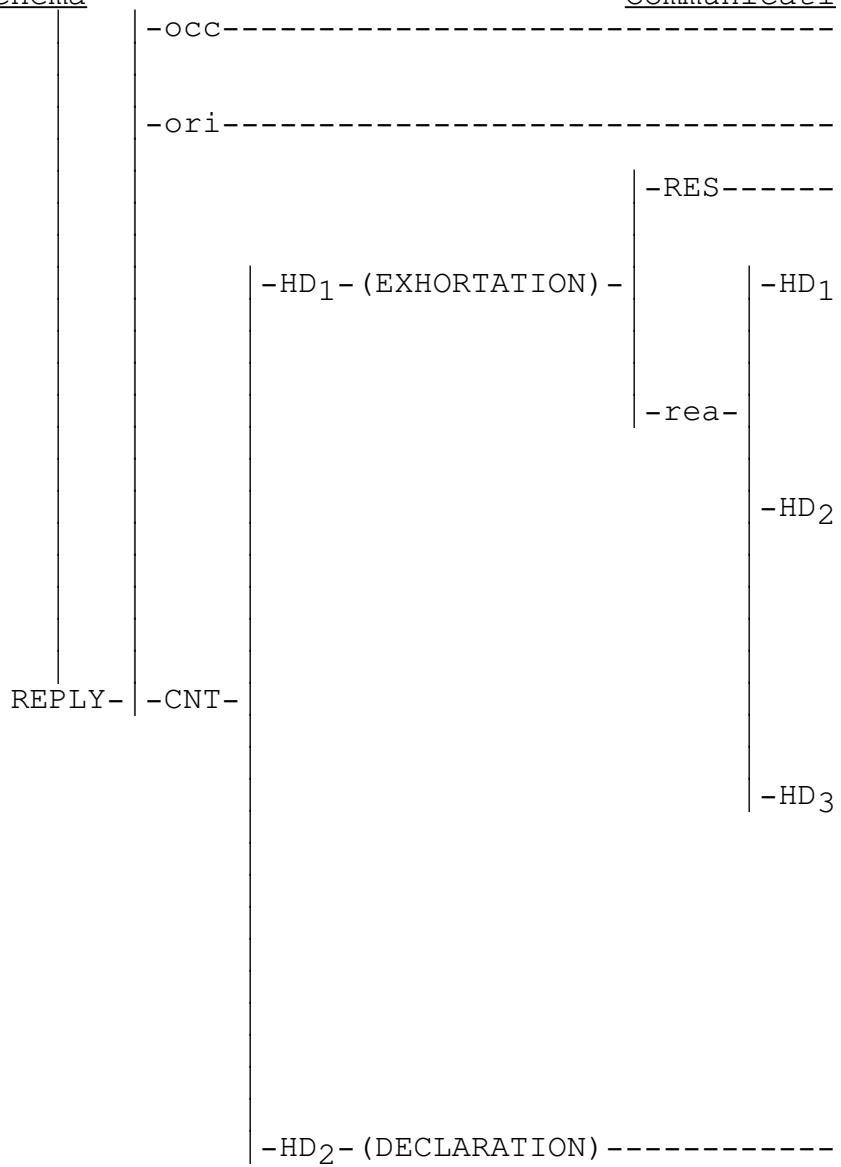

Episode Schema

Communicati



Episode Schema

Communicati

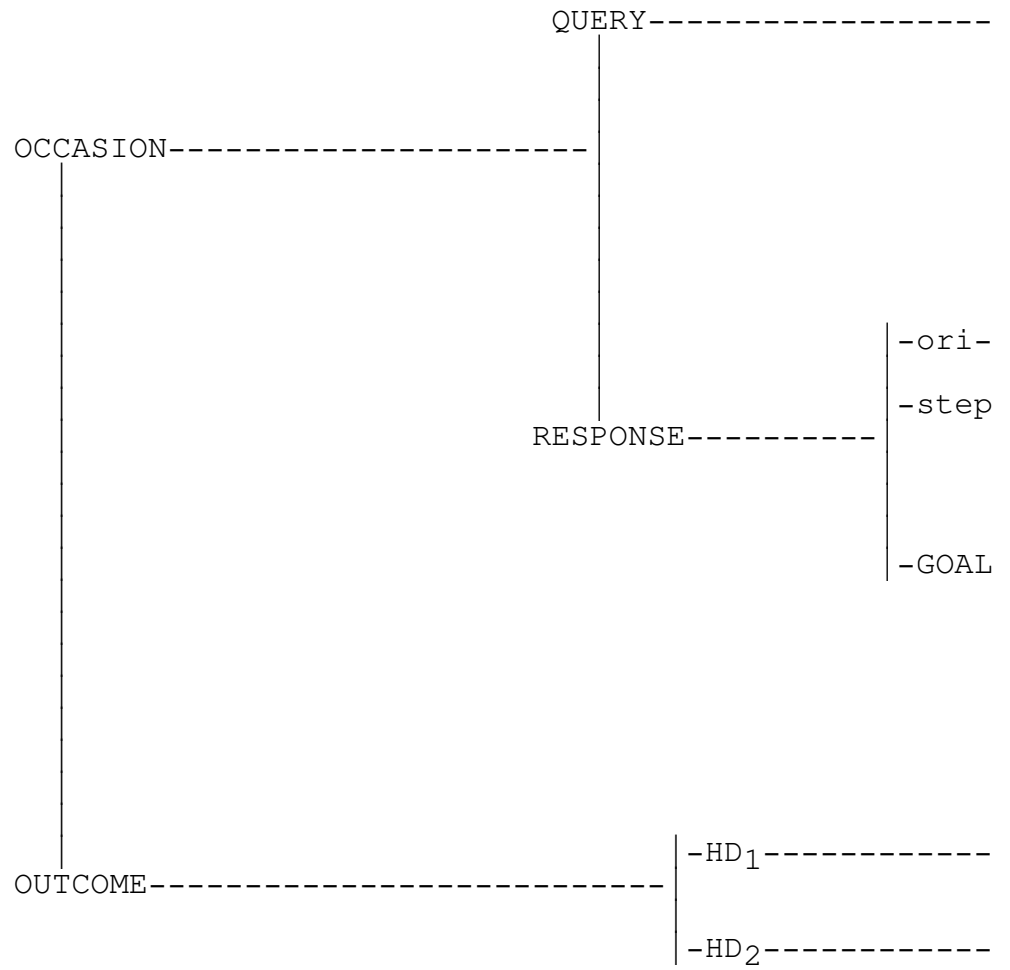

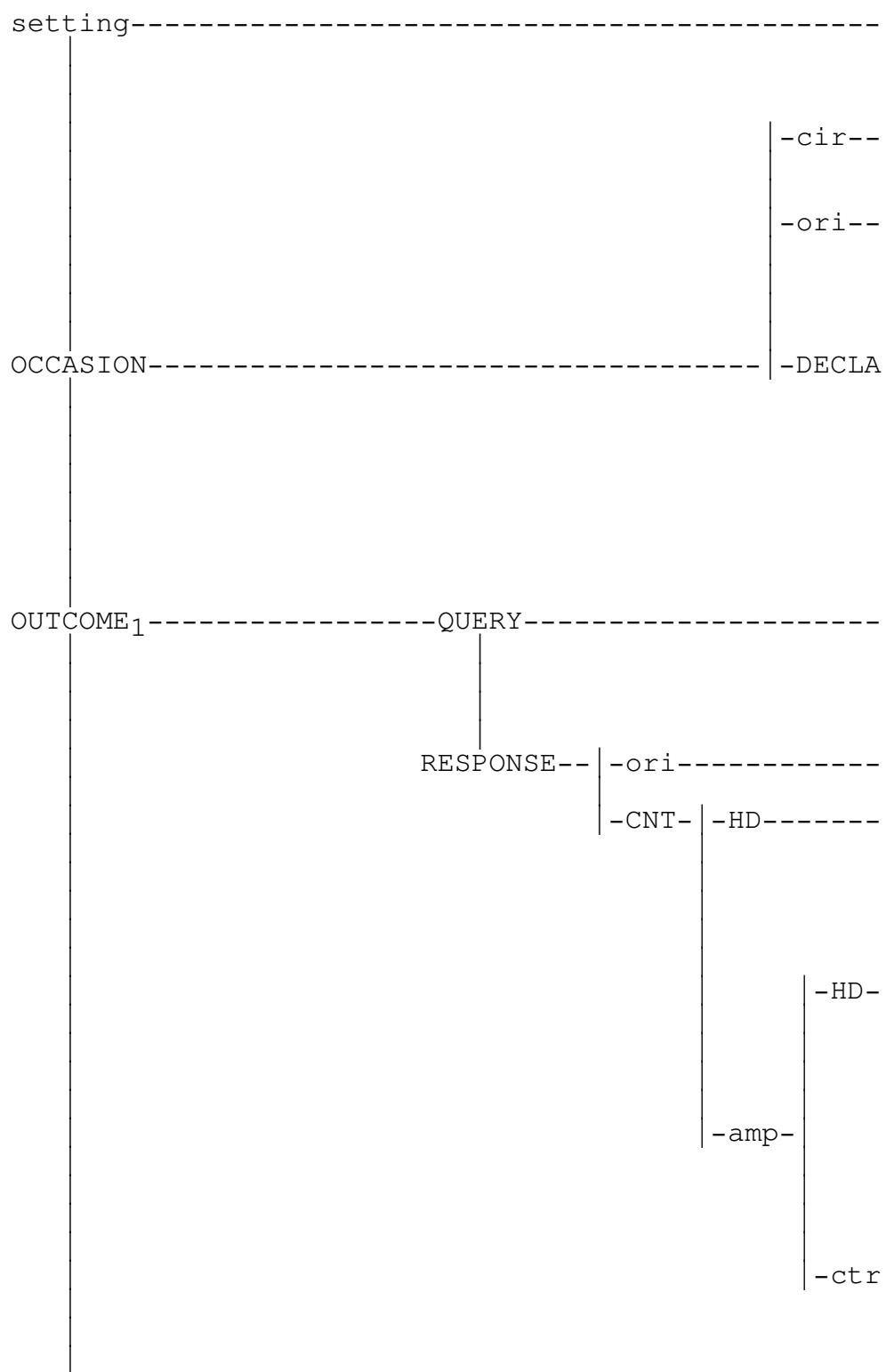
Episode SchemaCommunicati





Episode Schema

Communicati

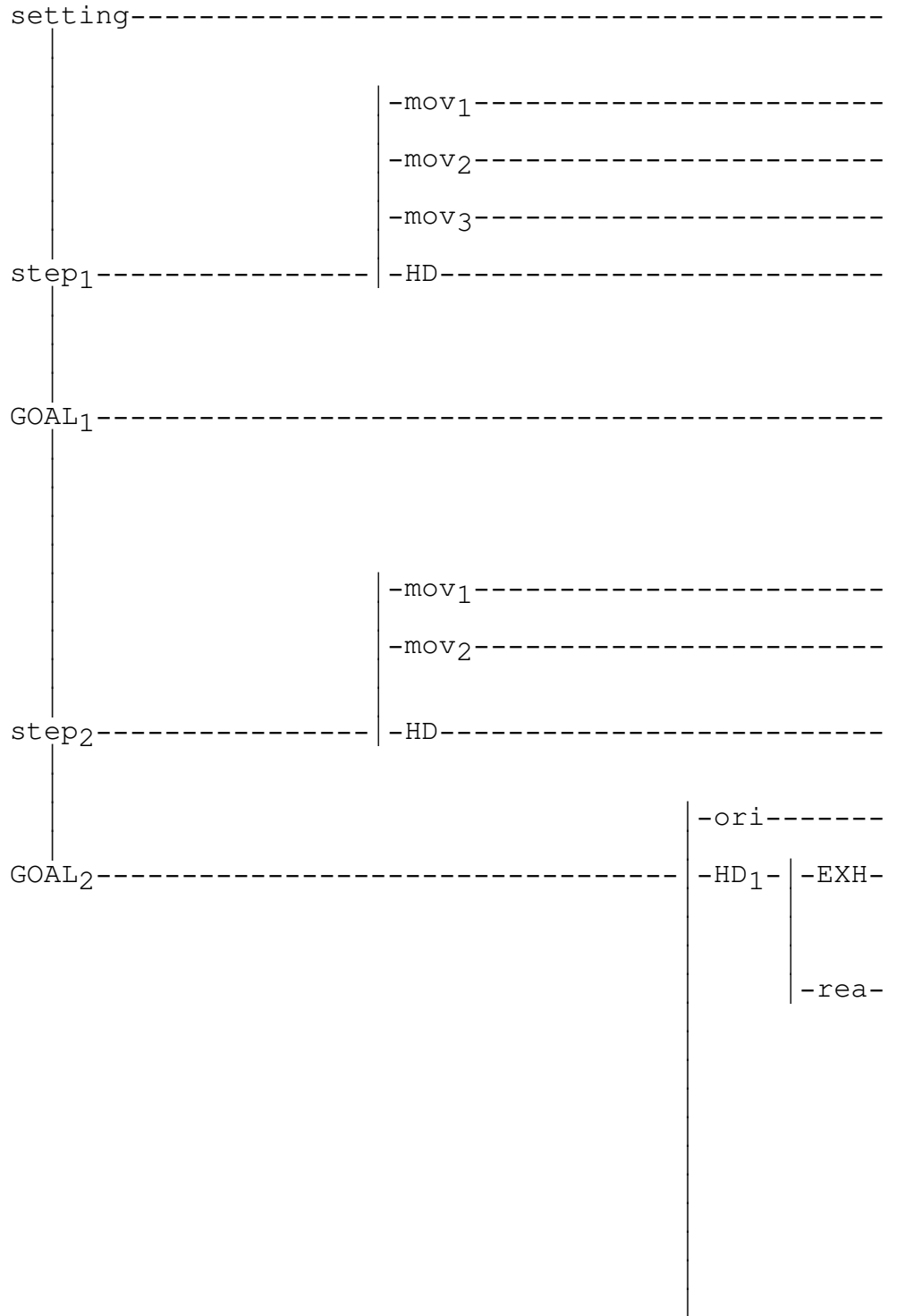

Episode Schema

Communicati

| -HD<sub>2</sub>-----

Episode Schema

Communicati

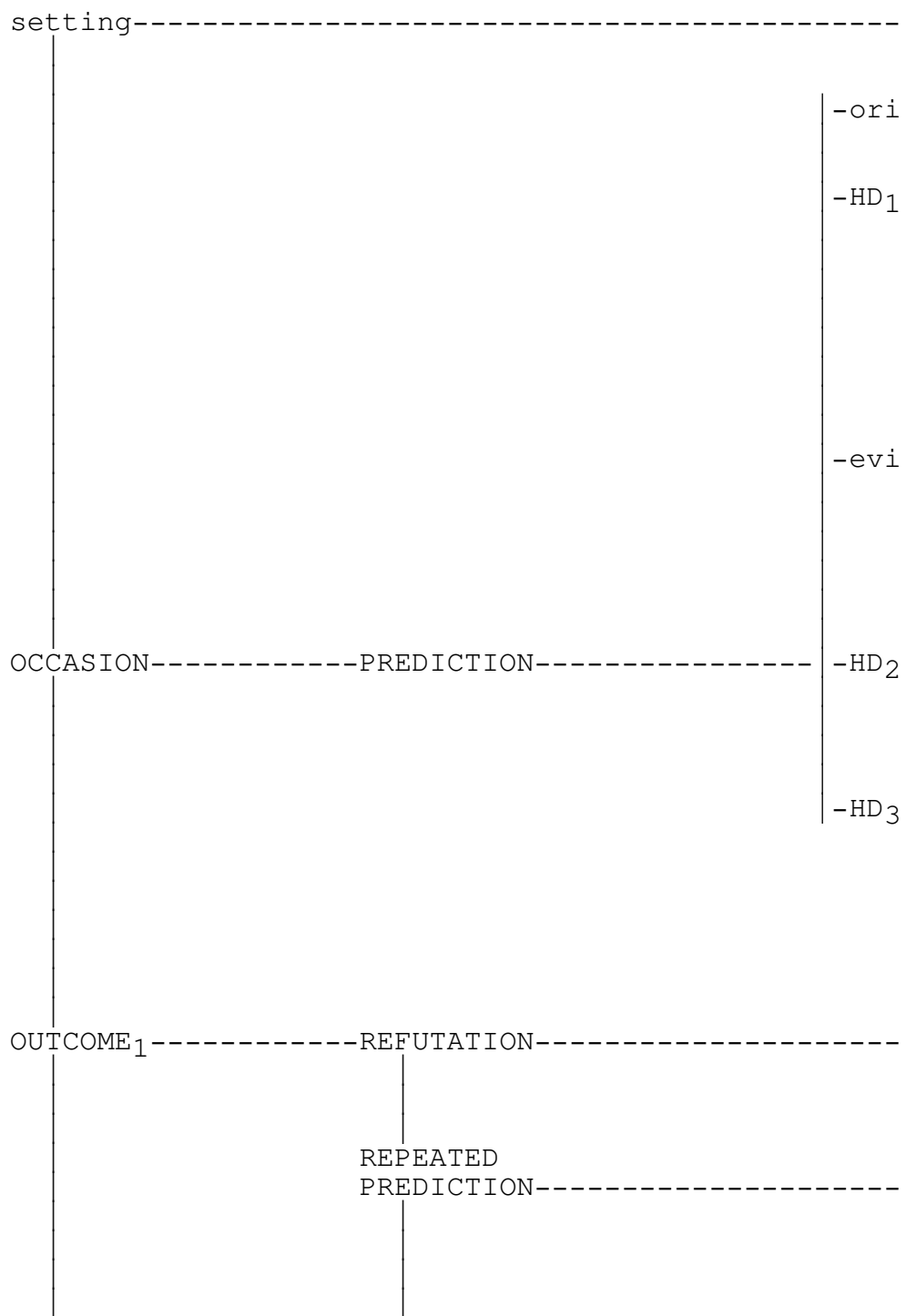

Episode Schema

Communicati

OUTCOME<sub>2</sub>

REPEATED  
REFUTATION

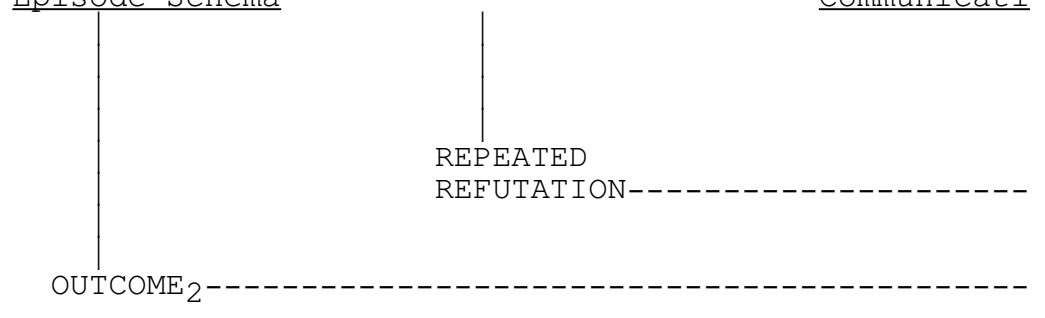

### Notes On The Communication Relations

1. The passover is a Jewish religious observance commemorating their deliverance from the angel of death and their flight from the land of Egypt.
2. 'Man from heaven' was chosen as a substitute for 'son of man.' The term 'son of man' is a technical religious term that will not be properly understood by the unchurched. 'Man from heaven' contains elements of both Christ's humanity and his deity, and should be readily understood by an average reader.
3. The feast of unleavened bread is a part of the passover observance. It commemorates the flight of the Jewish people from Egypt with unleavened bread as their provisions.
4. The Mount of Olives was located a short distance from the city of Jerusalem. It was customary for Jesus to frequent this place with His disciples.